



ILLINOIS DEPARTMENT OF NATURAL RESOURCES

Office of Oil and Gas Resource Management
One Natural Resources Way Springfield, Illinois 62702-1271



HIGH VOLUME HORIZONTAL HYDRAULIC FRACTURING PERMIT APPLICATION HVHFF-10

References to "1-xx" or "§1-xx" are to the Hydraulic Fracturing Regulatory Act., 225 ILCS 732/1-1 et seq.
References to "240.xxx" and "245.xxx" are to 62 Ill. Admin. Code 240 and 245, respectively.

Attachment: Hydraulic Fracturing Fluids and Flowback Plan

Please save attachment using the name above

Hydraulic Fracturing Fluids and Flowback Plan § 1-35 (b)(11); 245.210(a)(11), 245.825, 245.830, 245.850.
Please review the above-listed statute and rules, including the testing and reporting requirements found in Subpart H of the Rules, and describe the proposed methods for handling, storage, transportation and disposal of hydraulic fracturing fluids and flowback in sufficient detail to demonstrate that your plan for the materials meets the requirements of the statute and rules. In so doing, (a) identify, including name, identification number, specific location, and date of the most recent mechanical integrity test, the Class II injection well or wells to be used for disposal, reuse, or recycling of the fluid*; (b) explain the injection schedule, flow rate, reuse volume, storage, any treatment, and total volume in detail; (c) describe the capacity and qualities of tanks and any lined reserve pit to be used for capture and storage of flowback, the expected flowback rate and amount, and the frequency that the storage tanks will be emptied.

In so far as you will be recycling or reusing the hydraulic fracturing fluids and/or flowback, identify the name and address of said entity or facility accepting the fluid, the estimated amount of fluid to be reused or recycled, and the proposed purpose(s) said fluid will be used for.

If any part of the well or well site is in an area identified by the U.S. Geological Service as having a 2% or greater probability of exceedance in 50 years of peak ground acceleration of 0.4 standard gravity or more, identify measures you will take to protect the components in this plan against earthquakes of M 4.5 or more.

* Please contact the Office of Oil and Gas Resource Management at (217) 782-7756 for further information on specific Class II injection wells.



WOOLSEY OPERATING COMPANY, LLC

125 NORTH MARKET, SUITE 1000, WICHITA, KANSAS 67202-1775

(316) -267-4379 FAX (316) 267-4383

Woolsey Operating Company, LLC

Woodrow #1H-310408-193

White County, Illinois

High Volume Horizontal Hydraulic Fracturing Permit Application

HVHHF-10: Hydraulic Fracturing Fluids and Flow back Plan

The Class II injections wells that are planned to be used for disposal are:

Rankin #1 SWD, Reference #11947, SE N/2 NE, Sec 31-3S-11E, White County, IL.,

MIT Date; 9/20/2013

Trueflow #1, Reference #216072, SE SW SW, Sec 6-6S-9E, White County, IL., MIT

Date: 3/27/2015

All chemicals associated with the makeup of the Hydraulic Fracturing Fluid will be delivered by authorized carrier and stored on site in manufacturer's approved containers. The primary constituent of the Hydraulic Fracturing Fluid is fresh water and will not require any special handling. At the conclusion of HVHHF operations any remaining unused chemicals will be returned to the manufacturer in the same container. As the chemicals are mixed and injected directly into the fracturing fluid from the manufacturer's containers, only fresh water will be stored in the makeup tanks. There will be one lined acid tank where bulk acid will be diluted and pumped ahead of the proppant fluid. When HVHHF Operations are complete any remaining dilute acid will be removed and hauled to an approved facility. All such Hydraulic Fracturing Chemicals will be removed from the well site within 60 days of the completion of HVHHF operations. The fracturing treatment fluids will be flowed into a flow back tank having a capacity of approximately 500 barrels. This "flow back tank" is a closed tank constructed of steel with a sufficient pressure rating and maintained in a leak-free condition for the express purpose of recovering flow back fluids. It is lined with a material resistant to; corrosion, erosion, swelling, deterioration or other damage as a result of exposure to the flow back fluids, see attached diagram. The tank is inspected routinely for corrosion. This tank will be used to separate any gas or proppant in the flow back fluid and measure the flow back fluid volume. Up to five (5) additional closed storage tanks that meet the requirements set out in 245.825(a) will be connected to the primary flow back tank for temporary storage of the flow back fluid (approx. 3,000 barrels of maximum onsite storage). Flow back fluid is comprised of treatment fluid used in the HVHHF operations being primarily 2-5% KCL (Potassium Chloride) with minor amounts of other treating chemicals listed in the Chemical Disclosure Report. Flow back operations will

occur at the wellsite on the drilling pad. The temporary storage tanks will be enclosed by earthen containment berms which will be of sufficient size to contain all of the possible flow back fluid temporary storage volume. The flow from the well will be regulated by an adjustable choke. Anticipated flow rates will be between 10 and 25 barrels per hour. The flow back fluid will be hauled on a 24 hour basis as needed. Multiple water transports will be available and will be undertaken by liquid oilfield waste haulers permitted by the Illinois Department of Natural Resources. Expected haul frequency will depend on the flow rate and the size of the truck available. Bobtail trucks commonly can haul 80 barrels at a time and transports 120 barrels. If, for any reason the fluid cannot be hauled timely or safely, the well will be closed in until the fluid can be hauled. There are no plans to use open pits for capture and store of flow back fluids. The primary site where the flow back fluid will be disposed of is the Haggard Well Service Rankin #1 Class II disposal facility located in White County, Illinois. A secondary site is the TrueFlo Solutions LLC Class II disposal facility located in White County, Illinois. Flow back fluids will not be disposed into the above referenced disposal wells until an electronic flowmeter is installed and approved by IDNR as stated in Section 245.850(g). As this would be the first well to undergo HVHWF operations there would be no recycled fluid to use. If, in the future additional HVHWF operations are undertaken a method to reuse or recycle flow back water could be derived. The well will be flowed until there is little or no proppant being produced. At that time flow back operations will cease and the well turned to production facilities. It is anticipated that between 4,000 and 5,000 barrels of flow back will be recovered prior to terminating flow back and beginning to produce the well through the production facilities. As defined per 245.110 of the Illinois Administrative Code: *"Flowback period" ends with either the well shut in or when the well is producing continuously to the flow line.* For this reason the bulk of the fluid recovered will be treated as produced fluid as it would be from any conventional well. Flow back fluids will be tested for the presence of volatile organic chemicals, semi-volatile organic chemicals, inorganic chemicals, heavy metals and naturally occurring radioactive material before being removed from the well site.

The wellsite lies outside of the area identified by the U.S. Geological Survey as having a 2% or greater probability of exceedance in 50 years of ground acceleration of 0.4 standard gravity or more.

Steel Tank

Bi-Level Coated

Overview:

21,000 gallon bi-level tanks from Rain for Rent have a standard "V" shaped floor for ease of draining all stored liquids completely through a 4" butterfly valve with Buna seals standard. This tank also has a standard vacuum pressure relief valve.

Features:

Store liquids with confidence with Rain for Rent's 21,000 gallon bi-level tank. Permanently attached axels for maximum maneuverability allow this 21,000 gallon tank to be moved with ease on the jobsite and a safety staircase ensures proper protection for workers on site. Epoxy coating offers chemical resistance and additional cleanliness for sensitive environmental applications.

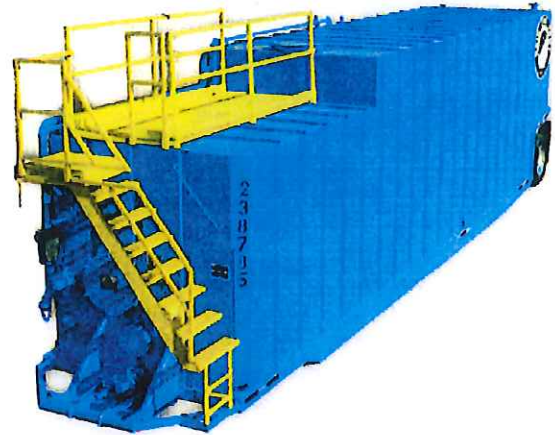

Specs:

Manways	Four 22" hatches
Material	Steel, Coated
Capacity	21,000 gallons
Dry weight	26,000 lbs.
Footprint (LxWxH):	516" x 96" x 141"

Accessories:

- Spillguard
- Suction and discharge piping
- Vapor tight features
- Level gauges
- Steam coils

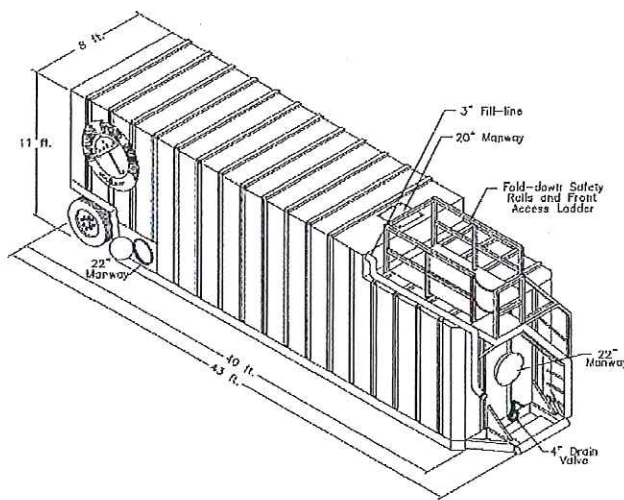

PUMPS • TANKS • FILTRATION • PIPE • SPILLGUARDS

Rain for Rent is a registered trademark of Western Oilfields Supply Company. Features and specifications are subject to change without notice.

Liquid ingenuity.™
800-742-7246
rainforrent.com