



Welcome to the Illinois Century Network (ICN)

Connectivity Process when Public K-12 procures Last Mile circuit to the ICN

This document provides guidance for public K-12 school district/school customers connecting to the ICN, where the public K-12 customer procures their own last mile connection to the ICN.

There are currently two methods for public K-12 customers to connect to the ICN. Either allow the DoIT E-rate consortium¹ to procure circuits on behalf of the public K-12 customer or the public K-12 customer procures the last mile circuit themselves.

When the DoIT E-rate consortium procures circuits on behalf of the public K-12 customer, this is done following E-rate rules to ensure subsidy is received for the circuits. E-rate rules requires following a competitive bidding process, extensive administration, and meeting required filing deadlines. Ensuring compliance with E-rate rules means there is a time lag between when the customer decides they want to connect to the ICN and when they actually connect to the ICN. For example, the E-rate funding year is from July 1st to June 30th the following year. The nine months prior to the start of the funding year is when competitive bidding is done, and funding requests filed. The benefit of having circuits procured via the DoIT E-rate consortium is that they are provided at no charge to public K-12. Costs are covered by the E-rate program and by state appropriation. The services provided by ICN are also at no charge. When a customer connects to the ICN via a last mile circuit procured via the consortium, the customer automatically receives the ICN Services. For example, if DoIT E-rate Consortium procures a 1 Gbps last mile circuit between a school head end and the ICN, the ICN also provides 1 Gbps of Internet access in addition to other ICN services such as auto distributed denial of service (DDOS) mitigation and firewall.

If a public K-12 customer wants to connect to the ICN, but does not want to wait for the next E-rate funding year, the customer can procure their own last mile circuit to the ICN. The public K-12 customer is responsible for the full cost of the connection or if the connection is subsidized via E-rate, the customer is responsible for the non-subsidized portion of cost. Once a connection is made to the ICN, ICN will provide ICN services at no charge to public K-12. With this approach, ICN can provide primary or backup service as soon as the interconnect is made. There is no need to wait for the next E-rate funding

¹ For information on the DoIT E-rate Consortium, and how to join the consortium, please see the 18 February 2021 webinar at www.doitconsortium.com under Webinars or directly at the following link: <https://multimedia.illinois.gov/doit/doit-erate-Consortium-Update-021821.html>

year. ICN staff also help facilitate this process with quotes, orders, installation, service turn up and ongoing monitoring and support.

The remainder of this document focusses on the scenario where the public K-12 customer connects to the ICN by procuring their own last mile circuit.

Architecture

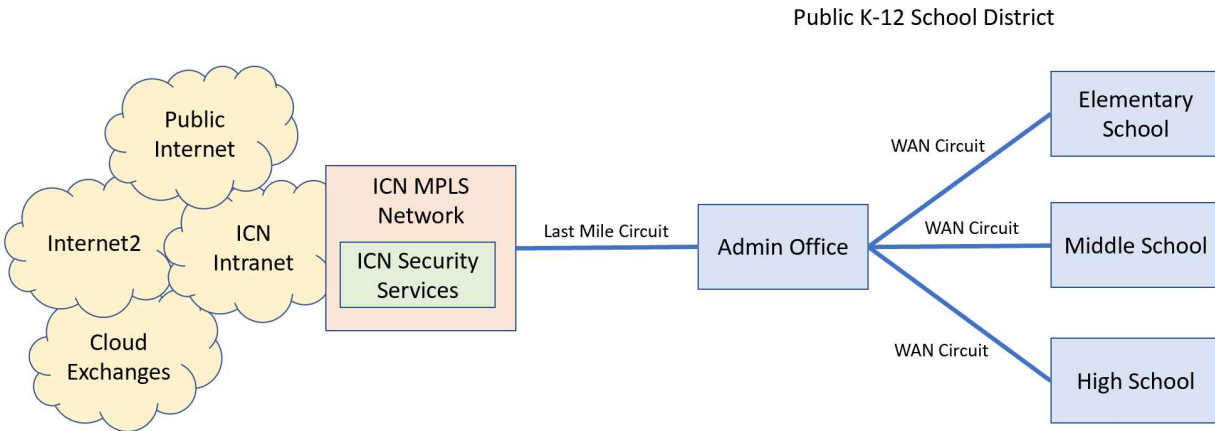

Figure 1. Public K-12 School District connection to ICN

Figure 1 shows the architecture for public K-12 connection to the ICN. The Last Mile circuit is from the school district head end or administration office to the ICN. The Last Mile circuit would connect to an ICN point of presence (POP). Within this document, the term Last Mile Provider refers to a service provider that has implemented this Last Mile Circuit.

Once connection to the ICN is made, ICN Services are provided at no charge. ICN Services consist of:

- Public Internet access
- ICN state intranet access
- Private point to point connections
- Auto Distributed Denial of service mitigation
- Centralized Firewall – ICN hosted
- CPE based firewall

These services are referred to as ICN Services throughout this document.

The Illinois Century Network (ICN) is a 2000 mile fiber network managed and maintained by the Illinois Department of Innovation and Technology (DoIT), an Illinois state agency. The ICN serves over 2000 customer locations, including K-12, libraries, higher education, state agencies, local municipalities, museums and retail service providers.

Service Turn Up Milestones

Customer selects ICN as their primary or backup Internet Service Provider - ICN staff prepare and emails the ICN Master Service Agreement (MSA) and Service Order (SO) to the customer for signature. These documents act as the contract/agreement between the customer and ICN. ICN will countersign the MSA and SO and return a fully executed copy to the customer. The SO will be for \$0. This documentation allows ICN to record and track the service being provided and allows the customer to agree to certain required obligations, such as acceptable use policy.

Customer selects a provider for the connection between the school and the ICN – customer informs ICN of the last mile provider name.

Meeting between customer and ICN staff – An ICN engineer, from the local Regional Technology Center (RTC) team, is assigned to the project and customer identifies their primary point of contact.

Technical information provided to customer - ICN engineer works with customer providing information on DNS services, IP addressing, routing hardware and any special configuration needs.

Technical information provided to Last Mile Provider - ICN engineer provides VLAN ID, collector circuit ID, and Point of Presence location

ICN is notified Last Mile Circuit install is complete - ICN engineer schedules site visit with customer to test circuit. If circuit is working correctly, ICN engineer and customer schedule network cut over and service turn up. If circuit is not working correctly, ICN engineer works with last mile provider to correct any problems.

Customer accepts service - ICN engineer provides customer with “network configuration document form” which includes all information about the customer connection, configuration, and ICN contact information.

IP Addresses:

ICN will provide public IP addresses for the customer LAN. Our standard IP address assignment is a /27 block of 32 addresses. ICN staff will provide the assigned block in advance of turning up the new service to give the customer time to prepare their LAN for the new network. ICN staff will identify the gateway address. Full Class C IP Address space is also available.

DNS:

ICN offers a full range of DNS services. Our two DNS servers are 206.166.1.109 & 206.166.1.110. ICN will host an unlimited number of zone records and act as the primary and/or secondary host. DNS additions and changes are made the same day. DNS requests may be made by emailing Doit.ICN.MSAhostmaster@illinois.gov, or contacting one of our Regional Technology Center (RTC) staff which may be found at <https://www.illinois.gov/icn/support/Pages/default.aspx>.

Providers with an Interconnect to the ICN

The list of providers that currently have an interconnect to the ICN are shown in the below table.

| | |
|--|---------------------------------|
| Adams TelSystems Inc | MCC Network Services |
| AT&T | McDonough Telephone |
| Bluebird Network | Mediacom |
| CIRBN, LLC | Northern Illinois University |
| Comcast | Shawnee Telephone |
| Consolidated Communications, Inc | Spectrum |
| Delta Communications DBA Clearwave | Sparklight |
| Frontier Communications | Stratus Networks Inc |
| Futura, LLC | Syndeo |
| Grafton Telephone | UC2B |
| Harrisonville Telephone | Vero Fiber Networks |
| Illinois Fiber Resources Group, NFP dba iFiber | Wabash Independent Networks Inc |
| Illinois Rural Health Network (IRHN) | Windstream |
| Madison Communications | |